

## Dispositivo di centraggio DCPD40... Locator device DCPD40...

### Caratteristiche principali:

- Corpo in alluminio
- Alta precisione di posizionamento
- 1 possibilità di staffaggio
- Doppi steli piatti nitruati
- Boccole guida in bronzo
- Corsa stelo: 20, 40 mm
- Cilindro pneumatico integrato alesaggio 40 mm
- 3 fori d'alimentazione G1/8"
- Finecorsa induttivo P+F (connessione M12x1)

### Main characteristics:

- Aluminum body
- High accuracy of positioning
- 1 mounting area
- Double nitrided plate rods
- Bronze guiding bush
- Rod stroke: 20, 40 mm
- Integrated pneumatic cylinder bore 40 mm
- 3 feeding ports G1/8"
- Inductive proximity switch P+F (connection M12x1)

[PDF](#)

[3D Step](#)



[Index](#)

### Indice.

### Index.

Pagina Page	Descrizione Description	
1	Caratteristiche principali <a href="#">Main characteristics</a>	
2	Codice d'ordine <a href="#">Ordering example</a>	
3	Pagina dimensionale <a href="#">Dimensional page</a>	DCPD40W-AN...
4		DCPD40W-BN...
5		DCPD40.2-AN...
6		DCPD40.2- BN...
7	Proprietà / Schema finecorsa induttivo <a href="#">Properties / Diagram for inductive proximity switch</a>	
7	Schema pneumatico <a href="#">Pneumatic plan</a>	
8	Ricambi / <a href="#">Spare parts</a> Note / <a href="#">Notes</a>	

## Codice d'ordine. Ordering example.

DCPD40W	-	AN	-	06	-	40	-	IR						
<p><b>Modello e alesaggio cilindro:</b> <b>Type and cylinder bore:</b></p> <p><b>DCPD40W</b> centratore doppio con attacco 55 mm e cilindro pneumatico alesaggio 40 mm <i>double locator with 55 mm mounting area and pneumatic cylinder bore 40 mm</i></p> <p><b>DCPD40.2</b> centratore doppio con attacco 40 mm e cilindro pneumatico alesaggio 40 mm <i>double locator with 40 mm mounting area and pneumatic cylinder bore 40 mm</i></p> 		<p><b>Posizione stelo:</b> <b>Rod Position:</b></p> <table border="1" style="margin-left: auto; margin-right: auto;"> <tr><td style="padding: 2px 10px;">06</td><td style="padding: 2px 10px;">12</td></tr> </table>	06	12		<p><b>Corsa:</b> <b>Stroke:</b></p> <table border="1" style="margin-left: auto; margin-right: auto;"> <tr><td style="padding: 2px 10px;">20</td><td style="padding: 2px 10px;">20 mm</td></tr> <tr><td style="padding: 2px 10px;">40</td><td style="padding: 2px 10px;">40 mm</td></tr> </table>	20	20 mm	40	40 mm		<p><b>Tipologia stelo:</b> <b>Rod type:</b></p> <p><b>AN:</b> stelo piatto nitrurato con 2 fori spina <i>nitrided plate rod with 2 dowel holes</i></p> <p><b>BN:</b> stelo piatto nitrurato con 1 foro spina <i>nitrided plate rod with 1 dowel hole</i></p> 		<p><b>Finecorsa:</b> <b>Proximity switch:</b></p> <p><b>X:</b> senza finecorsa <i>without proximity switch</i></p> <p><b>IL:</b> finecorsa induttivo P+F montato sul lato sx <i>inductive proximity switch P+F mounted on the left side</i></p> <p><b>IR:</b> finecorsa induttivo P+F montato sul lato dx <i>inductive proximity switch P+F mounted on the right side</i></p> <p><b>N.B.:</b> <u>i fori d'alimentazione si trovano sullo stesso lato del sensore induttivo</u> <b>NOTE:</b> <u>the feeding ports are always on the same side of the proximity switch</u></p> 
06	12													
20	20 mm													
40	40 mm													



## DCPD40W-AN...

Centratore, D.40, doppio stelo, 20/40mm, 2 fori spina, fiss. 55mm  
 Locator dev., D.40, double rod, 20/40mm, 2 dowel holes, fix. 55mm

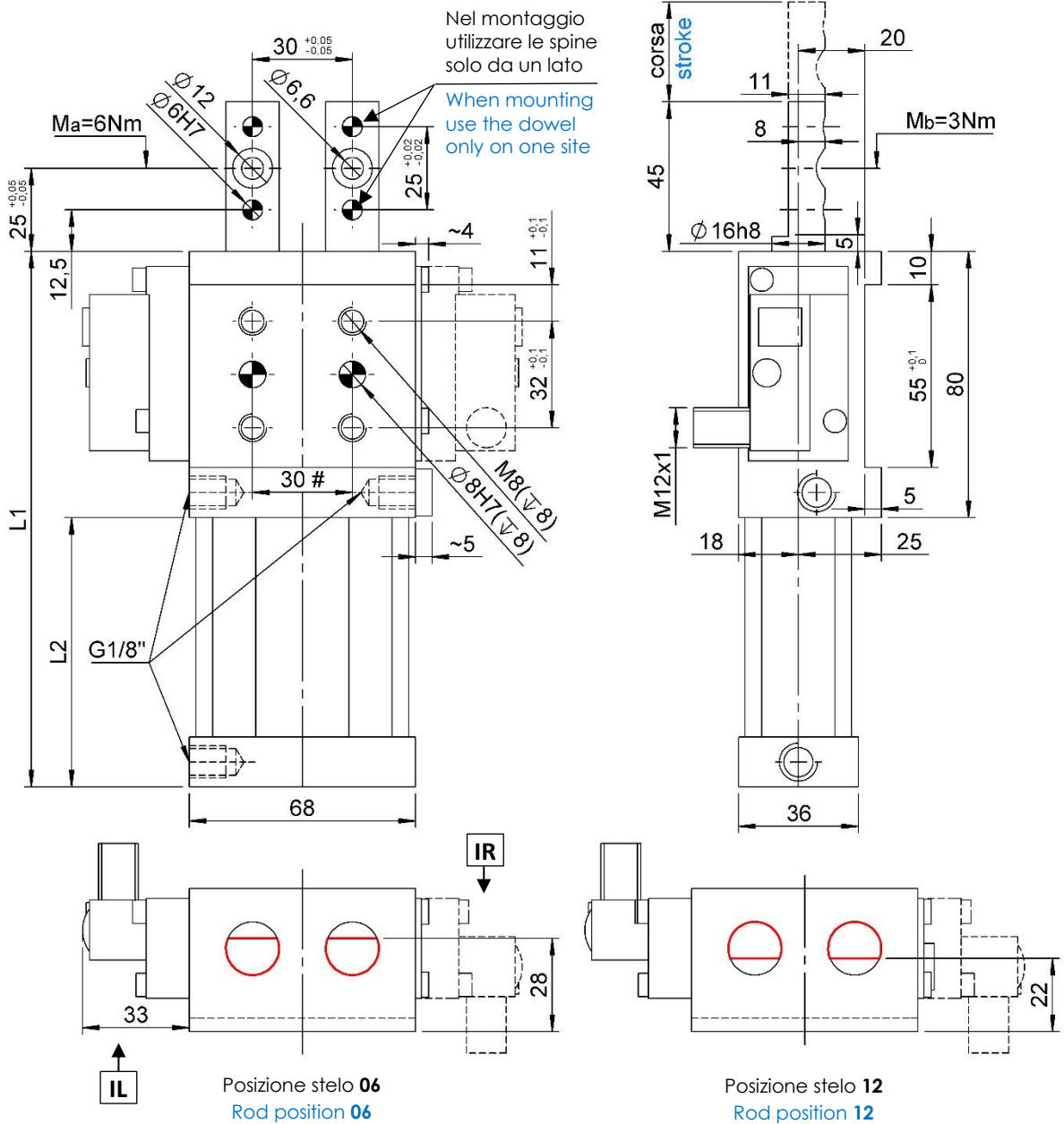

#Tolleranze: fori spina  $\pm 0.02$ , fori filettati  $\pm 0.1$   
 #Tolerances: dowel holes  $\pm 0.02$ , screw holes  $\pm 0.1$

Modello Type	Alesaggio cilindro Cylinder bore	Corsa stelo Rod stroke	L1	L2	Peso Weight	Consumo d'aria (5 bar) Air consumption (5 bar)
	[ mm ]	[ mm ]	[ mm ]	[ mm ]	[ Kg ]	[ l ]
DCPD40WAN-20I...	40	20	141	61	~1,1	~ 0,3
DCPD40WAN-40I...		40	161	81	~1,2	~ 0,5



## DCPD40W-BN...

Centratore, D. 40, doppio stelo, 20/40 mm, 1 foro spina, fiss. 55mm  
 Locator dev., D.40, double rod, 20/40mm, 1 dowel hole, fix. 55mm

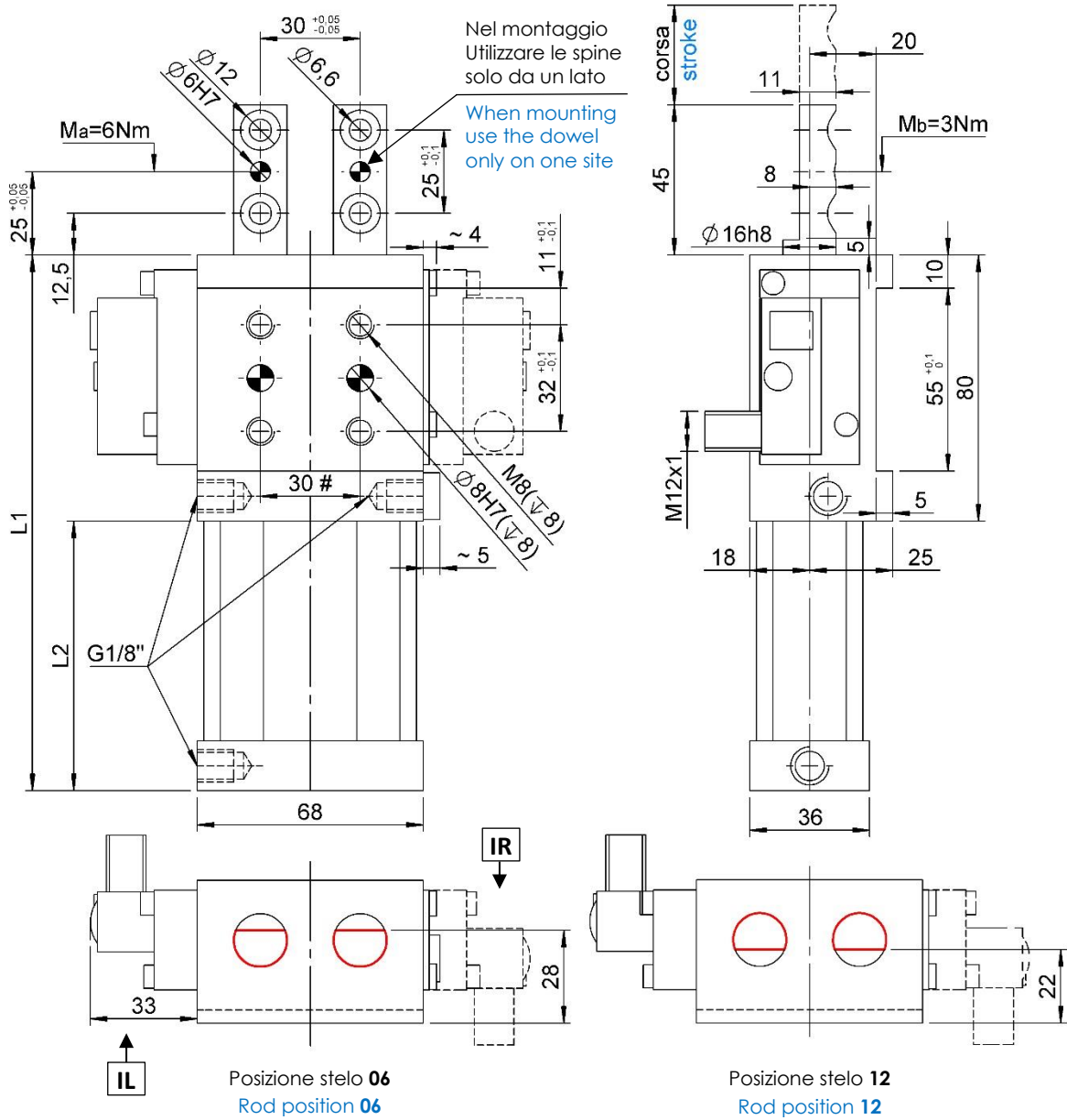

#Tolleranze: fori spina ±0.02, fori filettati ±0.1  
 #Tolerances: dowel holes ±0.02, screw holes ±0.1

Modello Type	Alesaggio cilindro Cylinder bore	Corsa stelo Rod stroke	L1	L2	Peso Weight	Consumo d'aria (5 bar) Air consumption (5 bar)
	[ mm ]	[ mm ]	[ mm ]	[ mm ]	[ Kg ]	[ l ]
DCPD40WBN-20I...	40	20	141	61	~1,1	~ 0,3
DCPD40WBN-40I...		40	161	81	~1,2	~ 0,5





## DCPD40.2 BN...

Centratore, D. 40, doppio stelo, 20/40 mm, 1 foro spina, fiss. 40mm  
 Locator dev., D.40, double rod, 20/40mm, 1 dowel hole, fix. 40mm

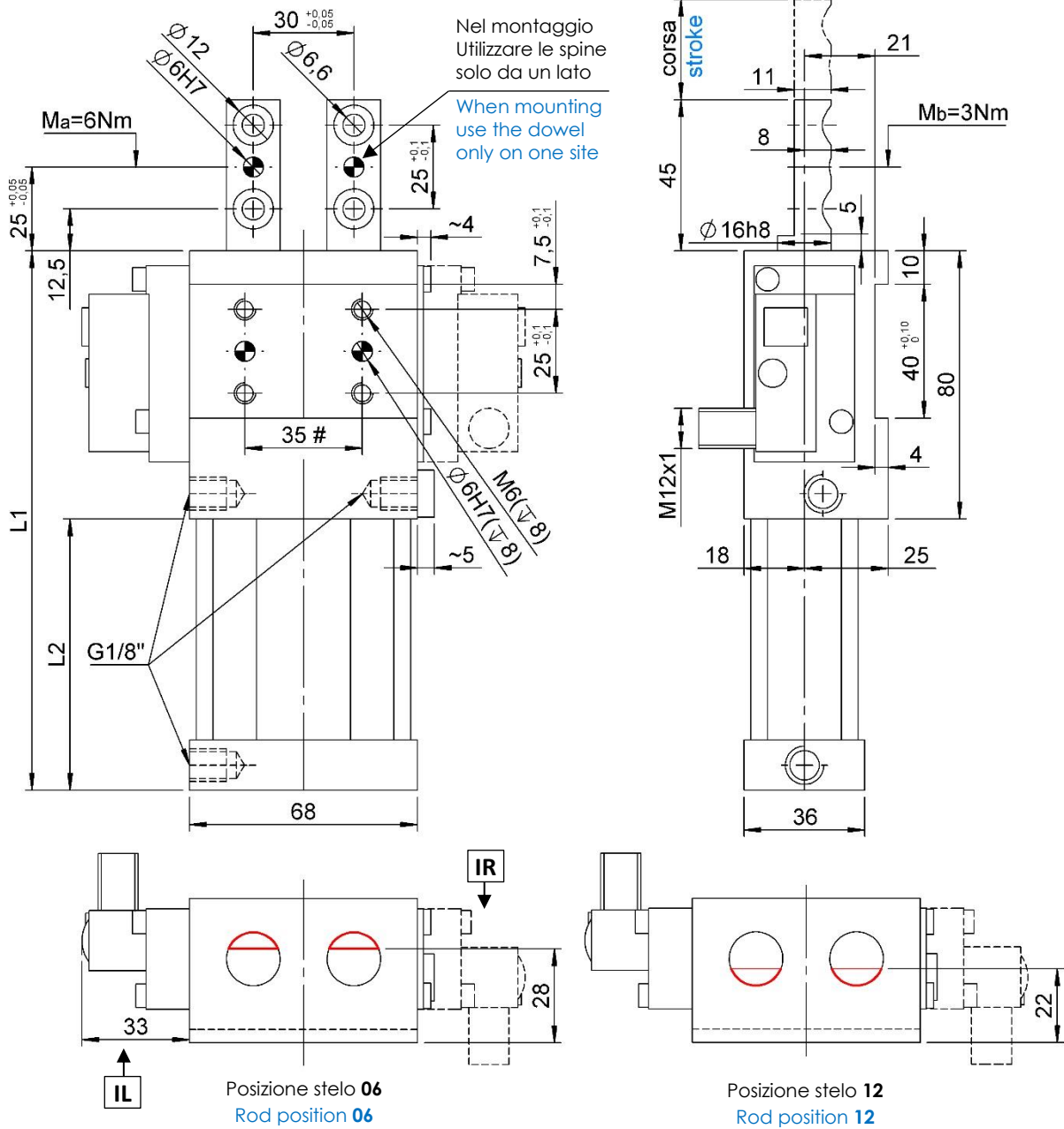

#Tolleranze: fori spina  $\pm 0.02$ , fori filettati  $\pm 0.1$   
 #Tolerances: dowel holes  $\pm 0.02$ , screw holes  $\pm 0.1$

Modello Type	Alesaggio cilindro Cylinder bore	Corsa stelo Rod stroke	L1	L2	Peso Weight	Consumo d'aria (5 bar) Air consumption (5 bar)
	[ mm ]	[ mm ]	[ mm ]	[ mm ]	[ Kg ]	[ l ]
DCPD40.2BN-20I...	40	20	141	61	~1,1	~ 0,3
DCPD40.2BN-40I...		40	161	81	~1,2	~ 0,5



## Proprietà.

## Properties.

Forza di spinta Pressing force (5 bar)	Forza di trazione Tensile force (5 bar)	Spinta radiale statica max. Static side force max.	Momento <b>Ma</b> max. Max. <b>Ma</b> torque	Momento <b>Mb</b> max. Max. <b>Mb</b> torque
[ N ]	[ N ]	[ N ]	[ Nm ]	[ Nm ]
600	500	80	6	3

## Schema Finecorsa induttivo (cod. 09576/corsa/C).

## Diagram for Inductive proximity switch (cod. 09576/stroke/C).

Caratteristiche tecniche (P+F):

- Tipo di uscita: PNP;
- Tensione d'alimentazione: 10-30 VDC;
- Corrente max. di commutazione: 200 mA;
- Consumo di corrente: < 25 mA;
- Calo di tensione: < 2 V
- Campo di temperatura: -25° / 70° C.

Technical data (P+F):

- Output type: PNP;
- Feeding voltage: 10-30 VDC;
- Max. commutating current: 200 mA;
- Power supply: < 25 mA;
- Voltage drop: < 2 V;
- Temperature range: -25° / 70° C.

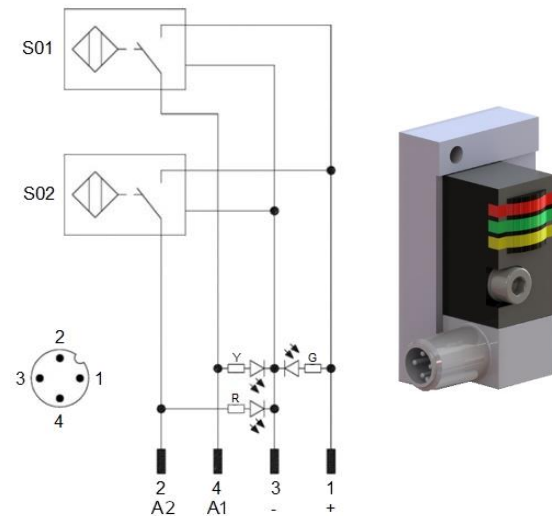

S01 = segnale d'apertura  
S01 = opening signal  
S02 = segnale di chiusura  
S02 = closing signal

Y = LED giallo / yellow LED  
G = LED verde / green LED  
R = LED rosso / red LED

1 = filo marrone / brown wire  
2 = filo nero / black wire  
3 = filo blu / blue wire  
4 = filo bianco / white wire

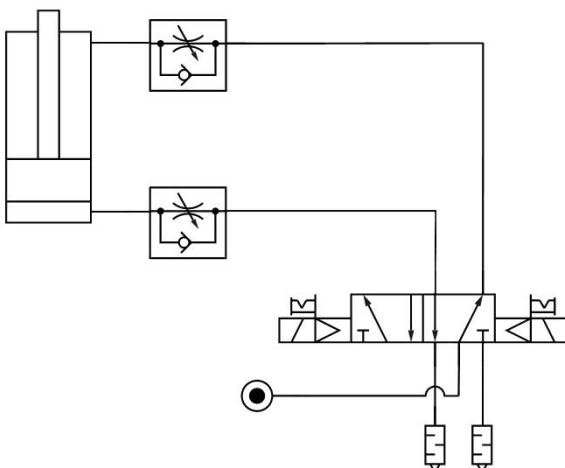

## Schema pneumatico.

## Pneumatic plant.



Modello Type	Consumo d'aria Air consumption (5 bar)	Consumo d'aria Air consumption (6 bar)	Pressione d'esercizio Working pressure
	[ l ]	[ l ]	[ bar ]
DCPD40W...-20l...	~ 0,3	~ 0,35	2 – 8
DCPD40.2...-20l...			
DCPD40W...-40l...	~ 0,5	~ 0,6	
DCPD40.2...-40l...			

**Ricambi****Spare parts**

# Kit	Immagine Picture	Descrizione Description	Articolo Article
<b>Finecorsa</b> <b>Proximity switch</b>		Finecorsa induttivo P+F Inductive proximity switch P+F	<b>09576/corsa/C</b> <b>09576/stroke/C</b>
<b>Kit guarnizioni</b> <b>Seals kit</b>		Guarnizioni cilindro pneumatico Pneumatic cylinder seals	<b>SCR-DCPD40W</b>

.....  
.....  
.....  
.....  
.....  
.....  
.....

Questo catalogo annulla e sostituisce i precedenti. Ci riserviamo la facoltà di apportare aggiunte o variazioni senza alcun preavviso. I prodotti a catalogo sono standard; eventuali richieste di applicazioni speciali vengono valutate dal servizio tecnico/commerciale. Tutta la documentazione è di proprietà della VEP Automation S.r.l. e senza autorizzazione è vietata qualsiasi tipo di riproduzione.

This catalogue cancels and replaces the previous ones. We reserve the right to make additions or changes without any notice. The products in the catalogue are standard; any enquiry of special applications is evaluated by technical/sales department. The complete documentation belongs to VEP Automation S.r.l. and without permission any kind of reproduction is forbidden.

**VEP Automation Headquarters****VEP Automation S.r.l**

Via San Felice, 37  
10092 Beinasco – Torino (Italy)  
Tel. +39 011 3972572  
Email: [info@vepautomation.it](mailto:info@vepautomation.it)  
Web: [www.vepautomation.it](http://www.vepautomation.it)

**VEP Automation Germany****VEP Automation GmbH**

Fritz Liebsch Str. 29  
D 26723 Emden (Germany)  
Tel. +49 04921 450758  
Email: [info@vepautomation.de](mailto:info@vepautomation.de)  
Web: [www.vepautomation.de](http://www.vepautomation.de)

**VEP Automation America****VEP Automation S.A. de C.V.**

Av. Toluca 373 M Col. Olivar de los  
Padres Del. Álvaro Obregón  
01780 CDMX – (Ciudad de México)  
Tel. +52 55 1718 0929  
Email: [info@vepautomation.mx](mailto:info@vepautomation.mx)  
Web: [www.vepautomation.mx](http://www.vepautomation.mx)

**VEP Automation China****VEP Automation (SUZHOU) CO.LTD**

Room 401, Building No 1, Liando U Valley, No 317  
Mudong Road, Mudu Town, Wuzhong District  
215156 Suzhou City (China)  
Tel.: +86 512 6575 3608  
Email: [info@vepautomation.cn](mailto:info@vepautomation.cn)  
Web: [www.vepautomation.cn](http://www.vepautomation.cn)